

# VOLVO PENTA INBOARD DIESEL

# MD2020

3-cylinder, freshwater-cooled marine diesel engine  
Crankshaft power\* 13.8 kW (19 hp)

\* Crankshaft power according to ISO 8665

The MD2020 is a marine engine of advanced design manufactured from quality components and designed to fulfil customer requirements.

## Service Life

The MD2020 is fitted with freshwater cooling as standard. This reduces internal corrosion and enables the engine to maintain a consistent and optimal working temperature under all conditions.

To avoid galvanic corrosion the engine is equipped with the unique electrical insulation between engine and transmission.

## Comfort

Smooth running with very low vibration levels results from a dynamically balanced design incorporating a flywheel of high rotating mass and high efficiency rubber insulation.

The engine's high torque provides excellent operating characteristics to aid maneuvering, particularly in confined spaces.

Additional on board comfort features are available from an extensive range of matched accessories.

## Environment

An advanced combustion system increases fuel burning efficiency to minimize noxious exhaust emissions and enhance overall enjoyment of boating.

## Transmissions

Five matched transmission options are available, each built for durability and smooth running.

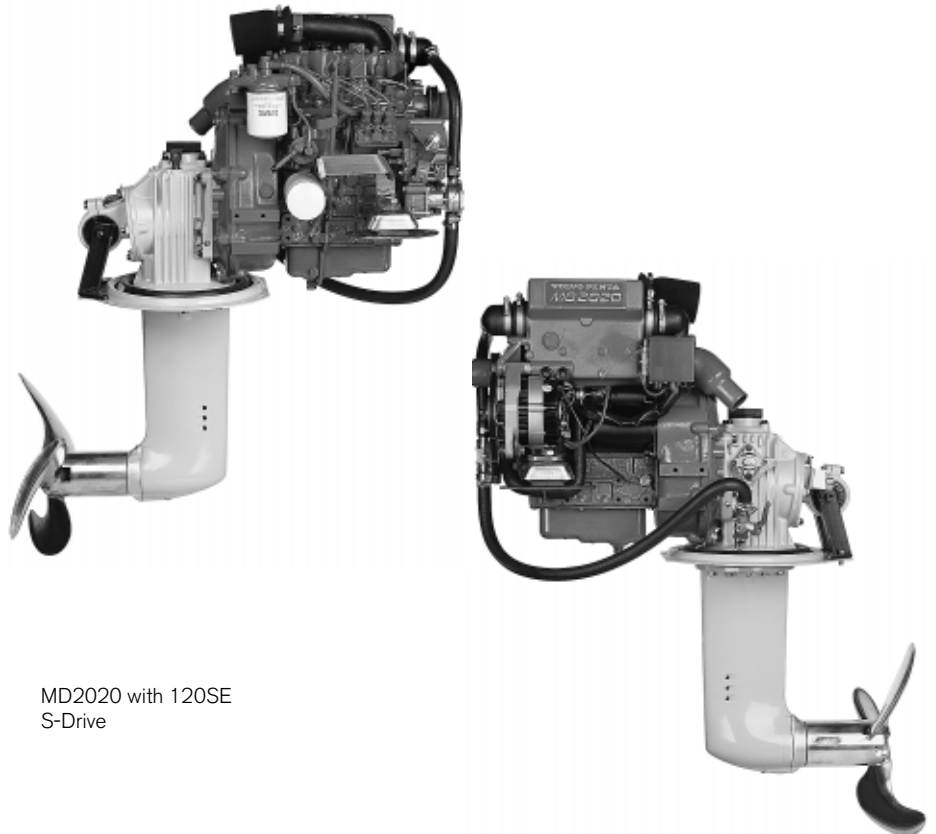

MD2020 with 120SE  
S-Drive

## Technical description:

### Engine and block

- Engine block and cylinder head manufactured from high grade cast iron. Crankcase features a rigid tunnel block design.
- Chrome molybdenum forged crankshaft, statically and dynamically balanced with integral counterweights. Pistons are cast from high silicon aluminum, are heat treated and fitted with two cast iron, chromium faced compression rings and a single oil ring.
- Replaceable, hardened valve seats
- Elastic coupling on flywheel

### Engine mounting

- Tuned front and rear cushion-type rubber mounts. Adjustable.

### Lubrication system

- Spin-on fullflow oil filter
- Separate oil scavenger pipe
- Closed circuit crankcase ventilation

### Fuel system

- Flange mounted, cam driven in-line injection pump

- Feed pump with hand primer
- Spin-on type fine fuel filter

### Exhaust system

- Freshwater cooled exhaust manifold and seawater cooled exhaust elbow

### Cooling system

- Freshwater cooling system governed by thermostat
- Tubular heat exchanger with integral expansion tank
- Coolant system prepared for hot water outlet fittings
- Easily accessible sea water pump and impeller

### Electrical system

- 12V corrosion-protected electrical system
- 14V/60A marine alternator
- Charging regulator with electronic sensor for voltage drop compensation
- Glow plugs for excellent cold starting
- Electric starter motor (0.7 kW output)
- Extension cable harness with plug-in connection available in various lengths

# VOLVO PENTA

# MD2020

## Choice of instrument panel:

Standard panel, including:

- Optional rev counter incl. hour counter
- Start button or key switch
- Alarm (for monitoring temperature, oil pressure and charge rate)
- Instrument panel lighting
- Switch for alarm test and glow

De Luxe panel including:

- Optional rev counter incl. hour counter
- Key switch
- Temperature gauge
- Oil pressure gauge
- Voltmeter
- Alarm (for monitoring temperature, oil pressure and charge rate)
- Instrument panel lighting
- Alarm test button

## Choice of transmissions:

MS2A – reverse gear with 7° down angle output. Ratio 2.4:1 or 3.0:1.

MS2L – reverse gear with straight output. Ratio 2.3:1 or 2.7:1.

120S – S-drive. Ratio 2.5:1.

- Housing of gravity die-cast aluminum alloy
- Pattern-matched helical cut gears
- Mechanical cone clutch shift
- Safety coupling with built-in overload protection
- Internal oil cooler (MS2)

## Accessories

- Engine controls and steering systems
- Additional instrument panels and instruments
- Extra alternator kits
- Battery and battery switches
- Hot water systems
- Separate expansion tanks
- Cooling water seacocks, strainers and hoses
- Exhaust systems and hull fittings
- Fuel systems including filters, pipes etc.
- Pulleys and universal brackets for power take-off (PTO)
- Propeller shaft systems and propellers
- Chemical products – paints, oils, cleaners etc.
- Kit for reverse installation of engine with S-drive (120S-E)

Contact your local Volvo Penta dealer for further information.

Not all models, standard equipment and accessories are available in all countries. All specifications are subject to change without notice.

The engine illustrated may not be entirely identical to production standard engines.

## Technical Data

Engine designation .....	<b>MD2020</b>
Crankshaft power, kW (hp) .....	13.8 (19)
Propeller shaft power <sup>1)</sup> , kW (hp) .....	13.3 (18)
Max engine speed, rpm .....	3200–3600
Displacement, l (cu. in.) .....	0.68 (41.3)
Number of cylinders .....	3
Bore/stroke, mm (in.) .....	67/64 (2.64/2.52)
Compression ratio .....	23.5:1
Dry weight with reverse gear MS2A/MS2L, kg (lb) .....	129 (284)
Dry weight with sail drive 120S, kg (lb) .....	137 (302)

Operating mode: R5 & R3

Technical data according to ISO 8665. Fuel with a lower calorific value of 42,700 kJ/kg and density of 840 g/liter at 15°C (60°F). Merchant fuel may differ from this specification which will influence engine power output and fuel consumption.

1) With MS2

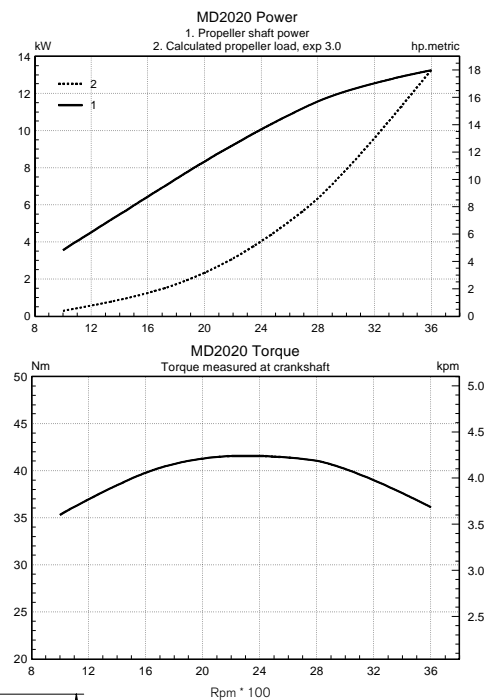

## Dimensions MD2020/MS2A/120S

Not for installation

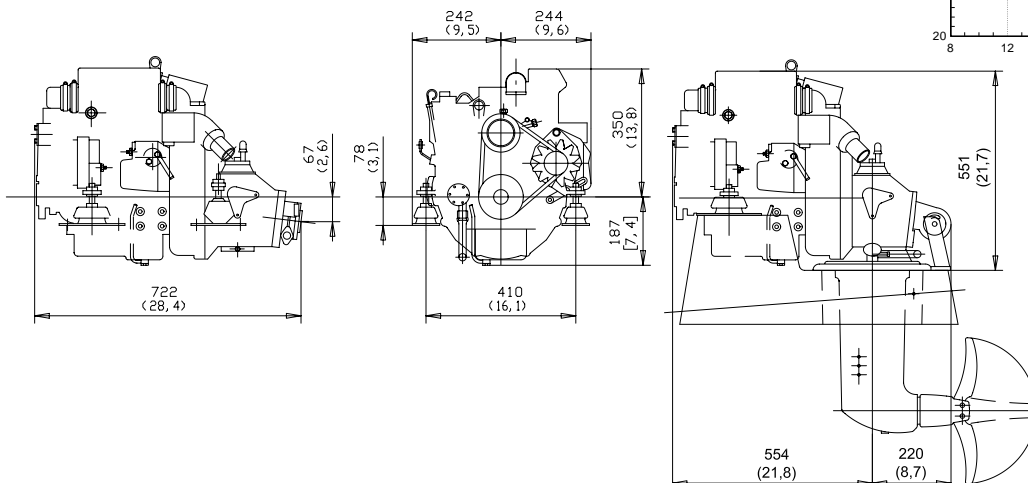

# VOLVO PENTA

**AB Volvo Penta**  
SE-405 08 Göteborg, Sweden